

Setting the standard in wireless zone control

WCZ-600 WIRELESS COMFORT™ ZONING

The WCZ-600 Wireless Comfort™ zone control system is a six zone, two-position, forced air zone control panel offering the latest in wireless thermostat and damper technology to greatly reduce installation time and labor costs.

BENEFITS:

- Eliminates costly installation of wiring thermostats and dampers.
- Allows contractors to offer zoning in applications once thought impossible to install.
- Universal control for single stage, multi-stage, heat pump and dual fuel systems (up to 4 heat / 2 cool).

FEATURES:

- PDM (Programming Display Module) guides the installer through all setup options.
- Wireless 915MHz proprietary protocol with up to 100 feet transmission range for thermostats and dampers.
- LEDs show zone and panel status.
- Redundant safety features protect equipment and maintain heating and cooling temperatures in the event of communications failure.
- 5 year warranty.

Wireless COMFORT™



**WIRELESS COMMUNICATIONS
BETWEEN THERMOSTATS, PANEL
AND DAMPERS!**



**MADE IN
USA**

WCZ-600 Wireless Comfort™ Zone Control Panel

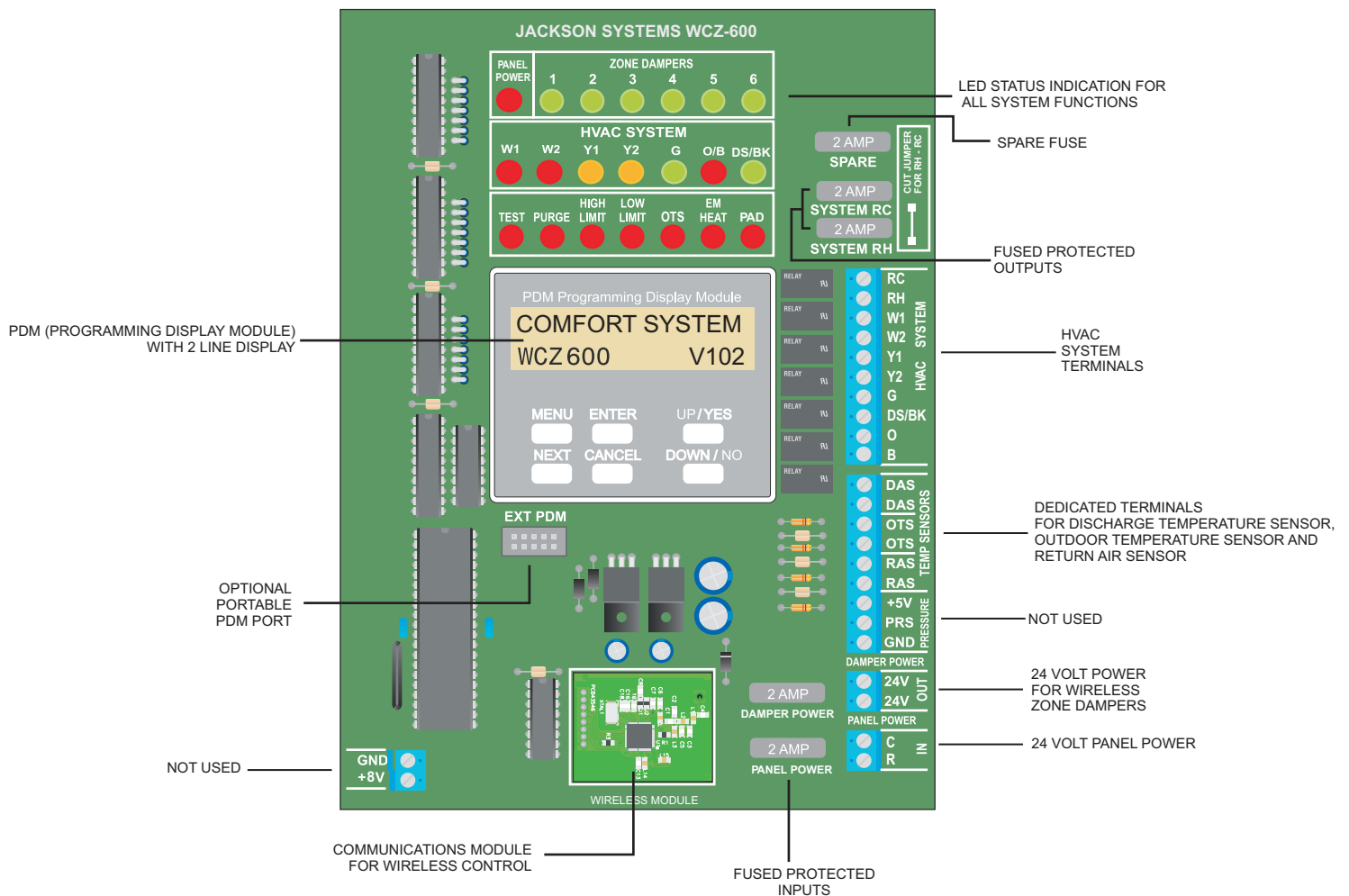

SPECIFICATIONS:

Compatible Equipment	Single stage, multi-stage, heat pump, dual fuel (Up to 4 heat / 2 cool)
HVAC System Terminals	RC, RH, W1, W2, Y1, Y2, G, DS/BK, O, B
Fan Operation	Gas or electric
LED Indication	Status for all zone equipment and panel functions
Communication	Wireless, 915MHz, proprietary protocol
Range	Up to 100 feet between panel and dampers, and panel and thermostats
Panel Power	24VAC, 40VA
Panel Dimensions	6" x 8" (W x H)
Panel Enclosure Dimensions	7" x 8" x 1.5" (W x H x D)

Specifications are subject to change without notice.

Jackson
SYSTEMS

Jackson Systems, LLC
Toll-Free: 888.652.9663 Fax: 317.227.1034
www.jacksonsystems.com

04-1053-011811